

Datasheet

Cloud L2+ Gigabit Managed Switch

WI-CMS310GF | WI-CMS318GF | WI-CMS328GF

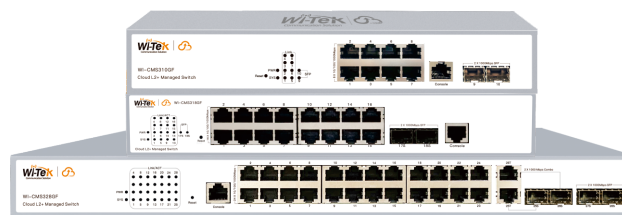

Overview

Wi-Tek Cloud L2+ Gigabit Managed Switch provide 8/16/24 gigabit ethernet RJ45 ports and multiple gigabit SFP uplink ports. Wi-Tek Cloud L2+ Gigabit Managed Switch can not only be managed by cloud platforms, but also support rich L2/L2+ management functions, such as static routing, port aggregation, and bandwidth control, providing powerful and reliable performance for your network solution, making it easy to manage and maintain.

Wi-Tek Cloud L2+ Gigabit Managed Switch provides a more efficient, simple, secure, and easy-to-use remote management method. It supports intelligent deployment, automatic networking configuration, abnormal alarms, and other functions.

The Wi-Tek Cloud L2+ Gigabit management switch provides a high-performance, reliable network solution with rich management capabilities that are perfect for the network access layer

Features

Double Fiber Slots Interface

Double gigabit SFP slots increase data transmission capacity, provide higher aggregation performance, and improve network stability and reliability. In addition, you can view the data traffic of the optical interface remotely.

The abundant Layer 2+ management features ensure network reliability

The Cloud L2+ Managed PoE switches support a complete lineup of L2 features, including 802.1Q VLAN, Port Mirroring, STP/RSTP/MSTP, ERPS, DHCP server, Link Aggregation Control Protocol, and 802.3x Flow Control function. Any more, the switch provides advanced features for network maintenance, such as Loopback Detection, Cable Diagnostics, and IGMP Snooping. Moreover, L2+ managed switches support L2+ feature-static routing, which is a simple way to provide segmentation of the network with internal routing through the switch and helps network traffic for more efficient use.

Cloud Platform Remote Management

Not only supports web interface and CLI management but also supports Wi-Tek Cloud platform remote management. Users can view the network status, modify the configuration, and troubleshoot at home.

Specifications



Model	WI-CMS310GF	WI-CMS318GF	WI-CMS328GF
Hardware Version	V1	V1	V1
Hardware Specifications			
Interfaces			
Downlink Ports	8 * 10/100/1000Mbps RJ45 Ports	16 * 10/100/1000Mbps RJ45 Ports	24 * 10/100/1000Mbps RJ45 Ports
Uplink Ports	2 * 1000Mbps SFP Slots	2 * 1000Mbps SFP Slots	2 * 1000Mbps Combo SFP Ports 2 * 1000Mbps SFP Slots
Management port	1 * Console Port	1 * Console Port	1 * Console Port
Performance			
Memory and Flash	128MB DDR3, 32MB Flash		
Switch Property			
Standards and Protocols	IEEE 802.3i: 10BASE-T Ethernet IEEE 802.3u: 100BASE-X Fast Ethernet IEEE 802.3ab: 1000BASE-T Gigabit Ethernet IEEE 802.3z: 1000BASE-X Gigabit Ethernet(Optical fiber)		
Forwarding Mode	Store and Forward		
Switching Capacity	20 Gbps	36 Gbps	56 Gbps
Packet Forwarding Rate	14.88 Mpps	26.78 Mpps	41.66 Mpps
MAC Address Table	8 k		
Packet Buffer Memory	4.1 Mbit		
Jumbo Frame	9216 Bytes		
Power Supply			
Input Power	AC 100~240V 50/60 Hz		



Model		WI-CMS310GF	WI-CMS318GF	WI-CMS328GF
Physical Characteristics				
LED Indicators	PWR: On: The switch is powered on Off: The switch is powered off or power supply is abnormal	PWR: On: The switch is powered on Off: The switch is powered off or power supply is abnormal	PWR: On: The switch is powered on Off: The switch is powered off or power supply is abnormal	PWR: On: The switch is powered on Off: The switch is powered off or power supply is abnormal
	SYS: Blinking: The switch works properly Off: The switch works improperly	SYS: Blinking: The switch works properly Off: The switch works improperly	SYS: Blinking: The switch works properly Off: The switch works improperly	SYS: Blinking: The switch works properly Off: The switch works improperly
	Link: On: Port connected Blinking: Data transmission Off: Port disconnected	Link/ACT: Orange on: The port is connected with 10/100Mbps speed Green on: The port is connected with 1000Mbps speed Blinking: Data transmission Off: Port disconnected	Link/ACT: Orange on: The port is connected with 10/100Mbps speed Green on: The port is connected with 1000Mbps speed Blinking: Data transmission Off: Port disconnected	Link/ACT: On: Port connected Blinking: Data transmission Off: Port disconnected
Fan Quantity	Fanless			
Product Dimensions	280 *180*44 mm		440*208*44mm	
Package Dimensions	370*230*80 mm		495*317*72 mm	
Weight	Net Weight: 1.34 kg	Net Weight: 1.49 kg	Net Weight: 2.50 kg	
	Package Weight: 2.09 kg	Package Weight: 2.30 kg	Package Weight: 3.30 kg	
Installation	Rack-Mounted, Desktop			
Button				
Reset	Hold for >5 sec.to restore factory default			
Environmental				
Reliability	Surge Immunity	IEC 61000-4-5 Common mode 4kV Differential mode 2kV		IEC 61000-4-5 Common mode 6kV Differential mode 4kV
	ESD Protection	IEC 61000-4-2 Contact discharge 6kV Air discharge 8kV		
Operating Environment	-10°C to 50°C, (14°F to 122°F) , 10%~90% RH no condensation			
Storage Environment	-40°C to 70°C, (-40°F to 158°F) , 5%~90% RH no condensation			



Model	WI-CMS310GF	WI-CMS318GF	WI-CMS328GF
Certification	CE, FCC, RoHS, UKCA, RCM		
Software Features			
QoS	8 priority queues		
	802.1p CoS/DSCP priority		
	Queue scheduling(SP (Strict Priority);WRR (Weighted Round Robin);SP+WRR		
	Bandwidth Control(Port/Flow based Rating Limiting)		
	Policy Config		
	Class-Map Config		
	Policy-Map Config		
	Policy Mark Config		
	Policy Bandwidth		
L2+	Policy VLAN		
	IPv4/IPv6 Interfaces		
	Static Routing(512 static routes)		
	Static ARP		
	8K ARP Entries		
	ARP timeout		
	Gratuitous ARP		
	DHCP Server		
	DHCP Relay		
Link Aggregation	DHCP L2 Relay		
	Static link aggregation		
	802.3ad LACP		
Spanning Tree Protocol	Up to 8 aggregation groups and up to 8 ports per group		
	802.1d STP		
	802.1w RSTP		
	802.1s MSTP		
STP Security: TC Protect, BPDU Filter, BPDU Protect, Root Protect, Loop Protect			



Model	WI-CMS310GF	WI-CMS318GF	WI-CMS328GF
Loopback Detection	Port-based		
	VLAN based		
Flow Control	802.3x Flow Control		
	HOL Blocking Prevention		
Mirroring	Port Mirroring		
	CPU Mirroring		
	One-to-One		
	Many-to-One		
L2 Multicast	Tx/Rx/Both		
	Supports IPv4/IPv6 IGMP groups		
	IGMP Snooping		
	IGMP v1/v2/v3 Snooping		
	Immediately-leave		
	IGMP Snooping Querier		
	IGMP Authentication		
	IGMP Proxy		
	MVR		
	MLD Snooping		
	MLD v1/v2 Snooping		
	Immediately-leave		
	MLD Snooping Querier		
	Static Group Config		
Limited IP Multicast			
Multicast Filtering			
VLAN	VLAN Group		
	Max. 4K VLAN Groups		
	802.1Q tag VLAN		
	MAC VLAN		
Protocol VLAN			



Model	WI-CMS310GF	WI-CMS318GF	WI-CMS328GF
VLAN	GVRP		
	Voice VLAN		
	Port-Based QinQ		
	Tunnel TPID (0x8100, 0x9100, 0x9200, Protocol ID)		
	OUI-Based VLAN		
Access Control List	MAC ACL		
	Source MAC		
	Destination MAC		
	Packet Type (Untagged-eth2, Untagged-802.3, Tagged-eth2, Tagged-802.3)		
	VLAN ID		
	Ether Type		
	IP ACL		
	Source IP		
	Destination IP		
	Fragment Packet		
	IP Protocol		
	IP Precedence		
	TCP/UDP Port		
	DSCP/IP TOS		
	Combined ACL		
	IPv6 ACL		
	icmp/tcp/udp		
	Mirroring		
	Attached Direction(Ingress/Traffic-statistic)		
	QoS Remark		
ACL apply to Port/VLAN			
Time-based ACL			



Model	WI-CMS310GF	WI-CMS318GF	WI-CMS328GF
Security	IP-MAC-Port Binding		
	DHCP Snooping		
	ARP Inspection		
	IPv4 secure-port		
Security	DHCPv6 Snooping		
	snooping remote-id		
	snooping subscriber-id		
	IPv6 security-ra		
	DoS Defend		
	DHCP Filter		
	Static/Dynamic Port Security		
	Broadcast/Multicast/Unicast Storm Control		
	kbps/pps control mode		
	802.1X		
	Port base authentication		
	Mac base authentication		
	VLAN Assignment		
	Guest VLAN		
	Support RADIUS authentication and accountability		
	AAA (including TACACS+)		
	Port Isolation		
	Secure web management through HTTPS with SSLv3/TLS 1.2		
	Secure Command Line Interface (CLI) management with SSHv1/SSHv2		
	IP/Port/MAC-based access control		



Model	WI-CMS310GF	WI-CMS318GF	WI-CMS328GF
IPv6	IPv6 Dual IPv4/IPv6		
	Multicast Listener Discovery (MLD) Snooping		
	IPv6 ACL		
	IPv6 Interface		
	Static IPv6 Routing		
	IPv6 neighbor discovery (ND)		
	Path maximum transmission unit (MTU) discovery		
	Internet Control Message Protocol (ICMP) version 6		
	TCPv6/UDPv6		
	IPv6 applications		
	DHCPv6 Client		
	Ping(v6)		
	Tracert(v6)		
	Telnet (v6)		
	Advanced Features	IPv6 SNMP	
IPv6 SSH			
IPv6 SSL			
Http/Https			
802.3ah Ethernet Link OAM			
ERPS			
Cloud Management			
ONVIF(ONVIF Detection,ONVIF Server(NLM))			
Batch Firmware Upgrading			
Intelligent Network Monitoring Abnormal Event Warnings			
Automatic Device Discovery			
Support Remote Management			
Support Cloud VLAN Configuration			
Support Topology Display			
Support Cloud Control Port Configuration			



Model	WI-CMS310GF	WI-CMS318GF	WI-CMS328GF
Management Features	Web-based GUI		
	Command Line Interface (CLI) through console port, telnet		
	SNMPv1/v2c/v3		
	Trap/Inform		
	RMON (1, 2, 3, 9 groups)		
	DHCP/BOOTP Client		
	802.1ab LLDP/LLDP-MED		
	CPU Monitoring		
	Cable Diagnostics		
	EEE		
	Password Recovery		
	SNTP		
System Log			
System	Ping		
	Traceroute		
	Firmware Upgrade		
	DDMI		

Appearances and Dimensions

WI-CMS310GF

Dimensions (mm)

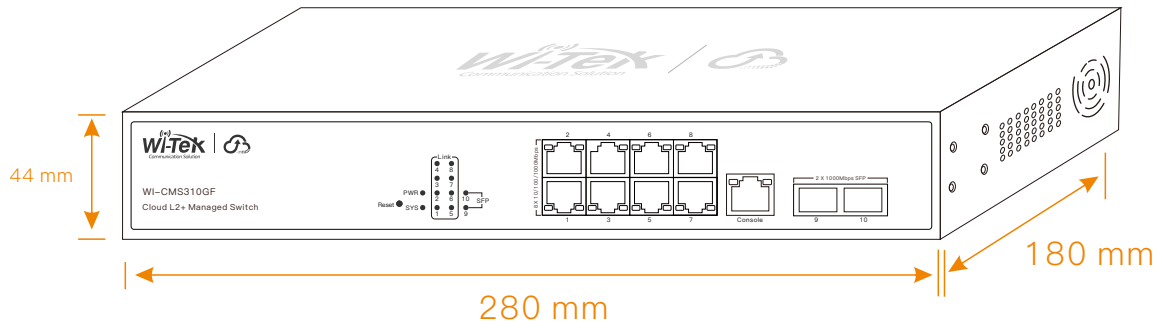

Front Panel

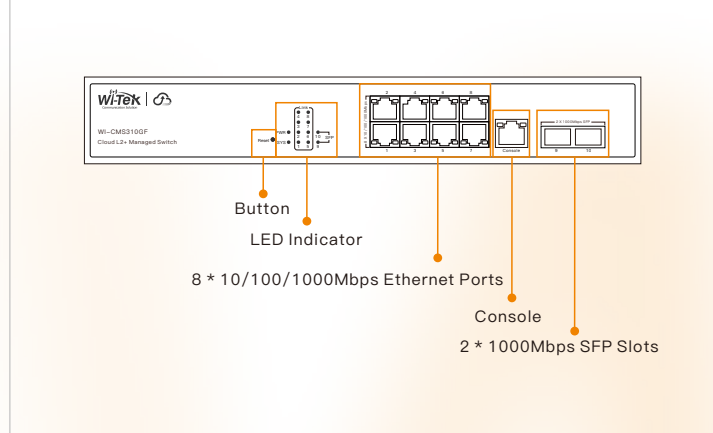

Side Panel

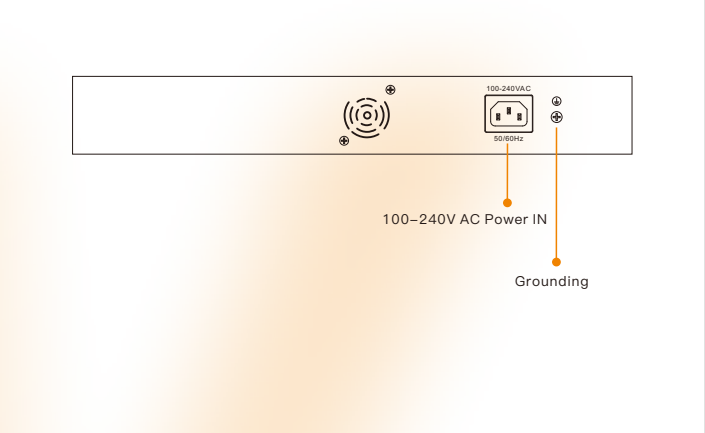

WI-CMS318GF

Dimensions (mm)

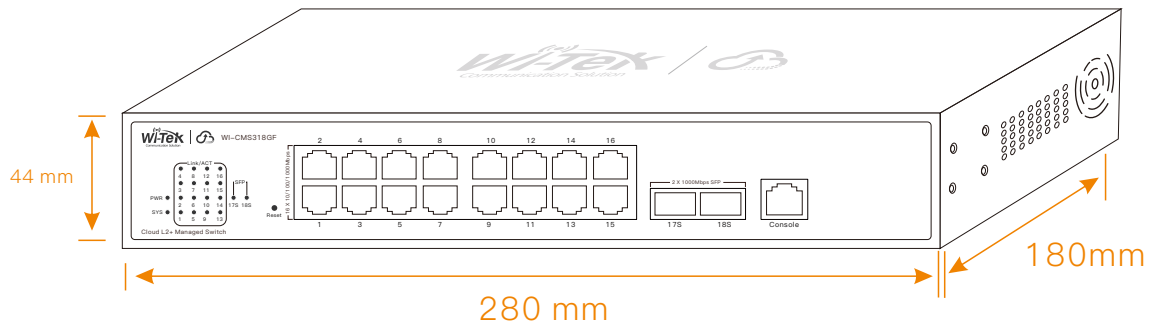

Front Panel

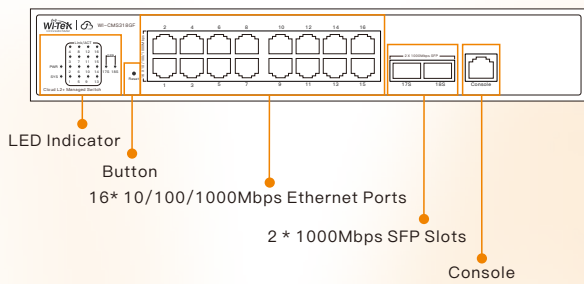

Side Panel

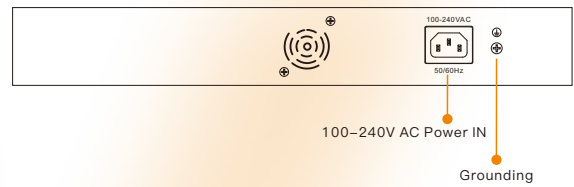

WI-CMS328GF

Dimensions (mm)

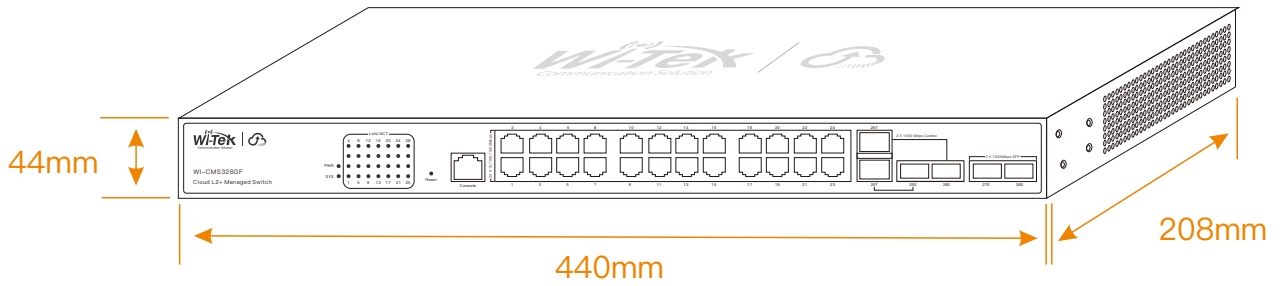

Front Panel

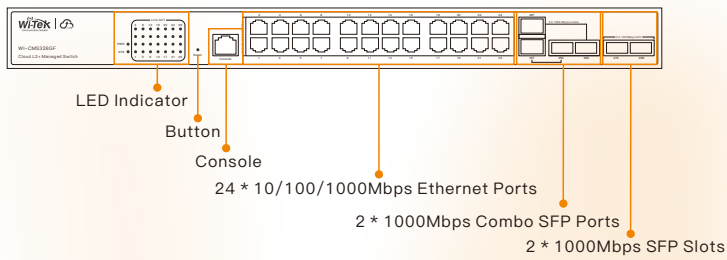

Side Panel

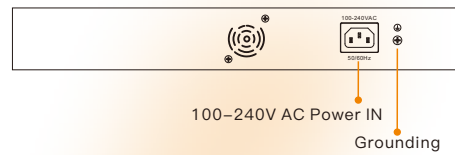

Package Contents

Welcome to order our products. After purchasing, you will receive:

Items	Quantity
Switch	1 pcs
Serial line	1 pcs
AC Power Cord	1 pcs
Rack mounting accessories(Hookx2; Matx4; Screwx8)	1 pcs
Quick Installation Guide	1 pcs



Wireless-Tek Technology Limited

Address: Building 3, Units 1801-1807, 1812, Huaqiang Era Plaza, Tangwei Community, Fuhai Street, Bao'an District, Shenzhen City, Guangdong Province, China.

Website: www.wireless-tek.com

Tel: 86-0755-32811290

Email: sales@wireless-tek.com

Technical Support: tech@wireless-tek.com



Technical Support



Cloud Management



Company Website